



SAFIT Srl

Via Casonetto,17
36050 Friola (VI)
-- ITALY --
Tel.0444 668335

**Technical Data Sheet
Steel toe cap**

Tabella Dimensionale

Puntali Acciaio

Type

Modello

522R

MADE IN ITALY

Written by: Nikola Kostic

Date: 07/01/2023

Rev.02

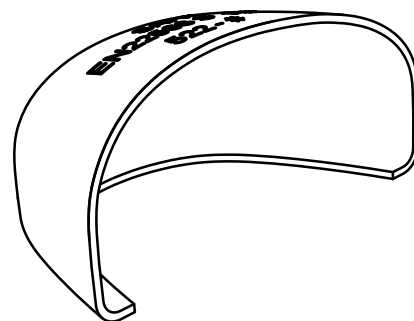
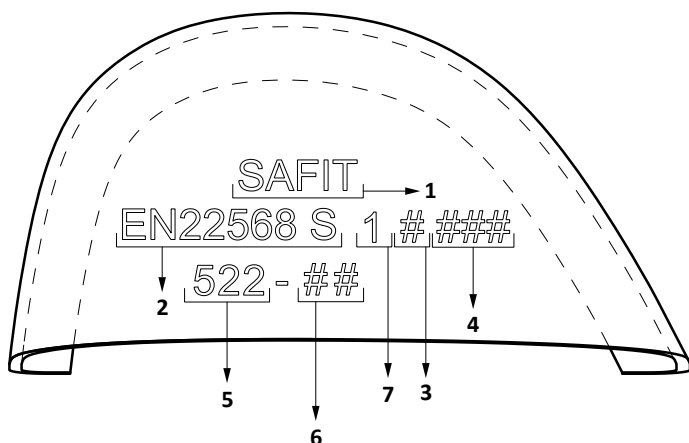
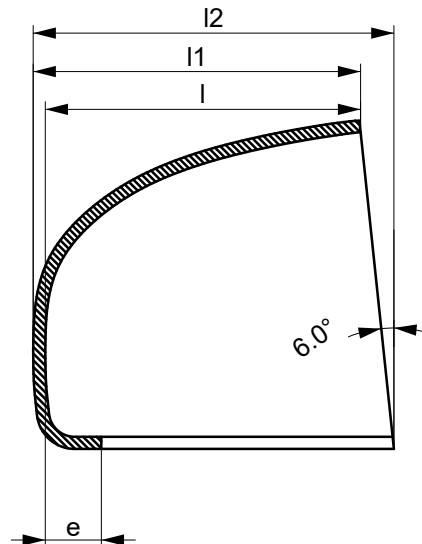
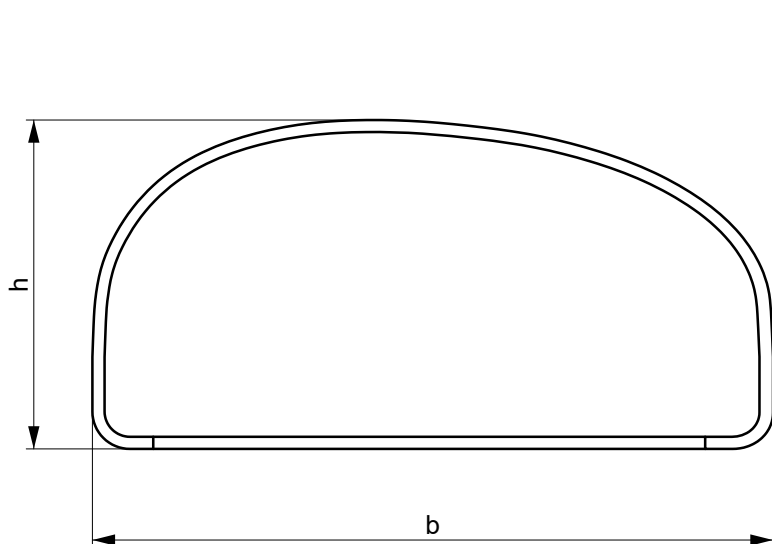

1	producer name
2	normative ref.
3	type A or B
4	batch number
5	model
6	size/R or L
7	metallic toe caps ref.

average hardness of steel releaved
on the top of the toe in the center position : HRc = 48 ± 2

dimension unit:		millimeter										KG		
Tolerance:		±0,05	±0,7	±0,5	±1	±1	±1	-2/ +2	Minimal requirement of		Average performance		± 0,010	
Size #	strip lenght - code ref.:	raw material thickness	b	h	l1	l2	l	e	ISO EN 22568:1 A	ISO EN 22568:1 B	200J	15KN	Weight (1 pairs)	
4														
5														
6		1,8	81,5	41,2	41,3	44,7	39,5	8,0	20,0	24,0	22,5	32,0	0,178	
7		1,8	85,4	41,8	39,8	47,5	38,0	8,0	20,5	24,5	24,5	33,0	0,181	
8		1,8	86,9	42,8	46,8	48,6	40,8	8,0	21,0	25,0	25,0	35,0	0,184	
9		1,8	89,8	44,2	43,2	48,8	41,4	8,0	21,5	25,5	27,0	34,5	0,201	
10		1,8	93,2	45,4	46,2	51,9	44,4	8,0	22,0	26,0	27,5	35,5	0,218	
11		1,8	95,9	46,9	47,0	52,4	45,2	8,0	22,0	26,0	26,5	36,0	0,228	
12		1,8	96,2	49,3	48,0	53,0	46,2	8,0	22,0	26,0	28,0	37,0	0,238	
Conformity to the norm Conforme alle norme				<input checked="" type="checkbox"/> ISO EN 22568:1 A				<input checked="" type="checkbox"/> ISO EN 22568:1 B			<input checked="" type="checkbox"/> ANSI/ASTM		<input checked="" type="checkbox"/> CSA	