



SAFIT Srl

Via Casonetto,17
36050 Friola (VI)
-- ITALY --
Tel.0444 668335

Technical Data Sheet

Steel toe cap

Tabella Dimensionale

Puntali Acciaio

Type

Modello

600

Written by: Nikola Kostic

Date: 01/12/2016

Rev.00

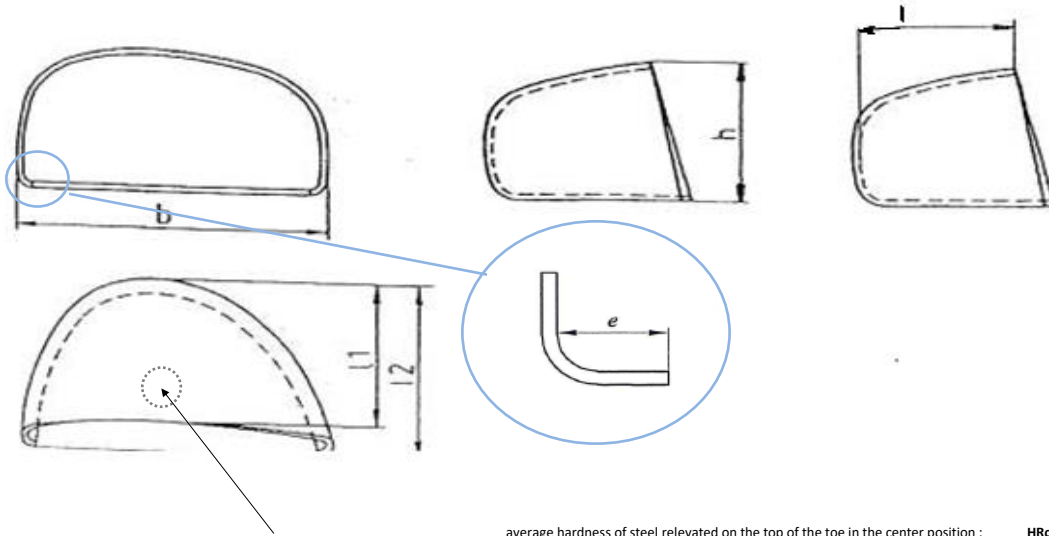

average hardness of steel releaved on the top of the toe in the center position : **HRC = 48 ± 2**

dimension unit:		millimetre										KG	
Tolerance:		±0,05	±0,7	±0,5	±1	±1	±1	-2/+2	Minimal requirement of		Average performance		± 0,010
Size #	strip length code ref.:	raw material thickness	b	h	l1	l2	l	e	ISO EN 22568:1 A	ISO EN 22568:1 B	200J	15KN	Weight (1 pair)
4													
5		1,8	79,4	39,0	44,3	48,0	42,5	8,0	19,5	23,5	22,0	31,5	0,157
6		1,6	81,7	41,7	45,0	48,5	43,4	8,0	20,0	24,0	22,5	32,0	0,160
7		1,6	85,5	41,0	46,2	50,1	44,6	8,0	20,5	24,5	23,5	33,0	0,160
8		1,6	85,4	43,5	47,5	51,5	45,9	8,0	21,0	25,0	23,5	33,5	0,172
9		1,5	86,7	44,1	48,2	52,0	46,7	8,0	21,5	25,5	25,7	34,0	0,172
10		1,5	88,5	45,5	50,5	54,5	49,0	8,0	22,0	26,0	26,2	35,4	0,178
11		1,5	88,6	46,2	52,3	56,5	50,8	8,0	22,0	26,0	26,5	36,0	0,184
12													
Conformity to the norm		<input checked="" type="checkbox"/> ISO EN 22568:1 A			<input type="checkbox"/> ISO EN 22568:1 B			<input checked="" type="checkbox"/> ANSI/ASTM			<input checked="" type="checkbox"/> CSA		
Conforme alle norme													