



SAFIT Srl

Via Casonetto,17
36050 Friola (VI)
-- ITALY --
Tel.0444 668335

MADE IN ITALY

**Technical Data Sheet
Steel toe cap**

Tabella Dimensionale

Puntali Acciaio

Type

Modello

AHG

Written by: Nikola Kostic

Date: 07/01/2023

Rev.02

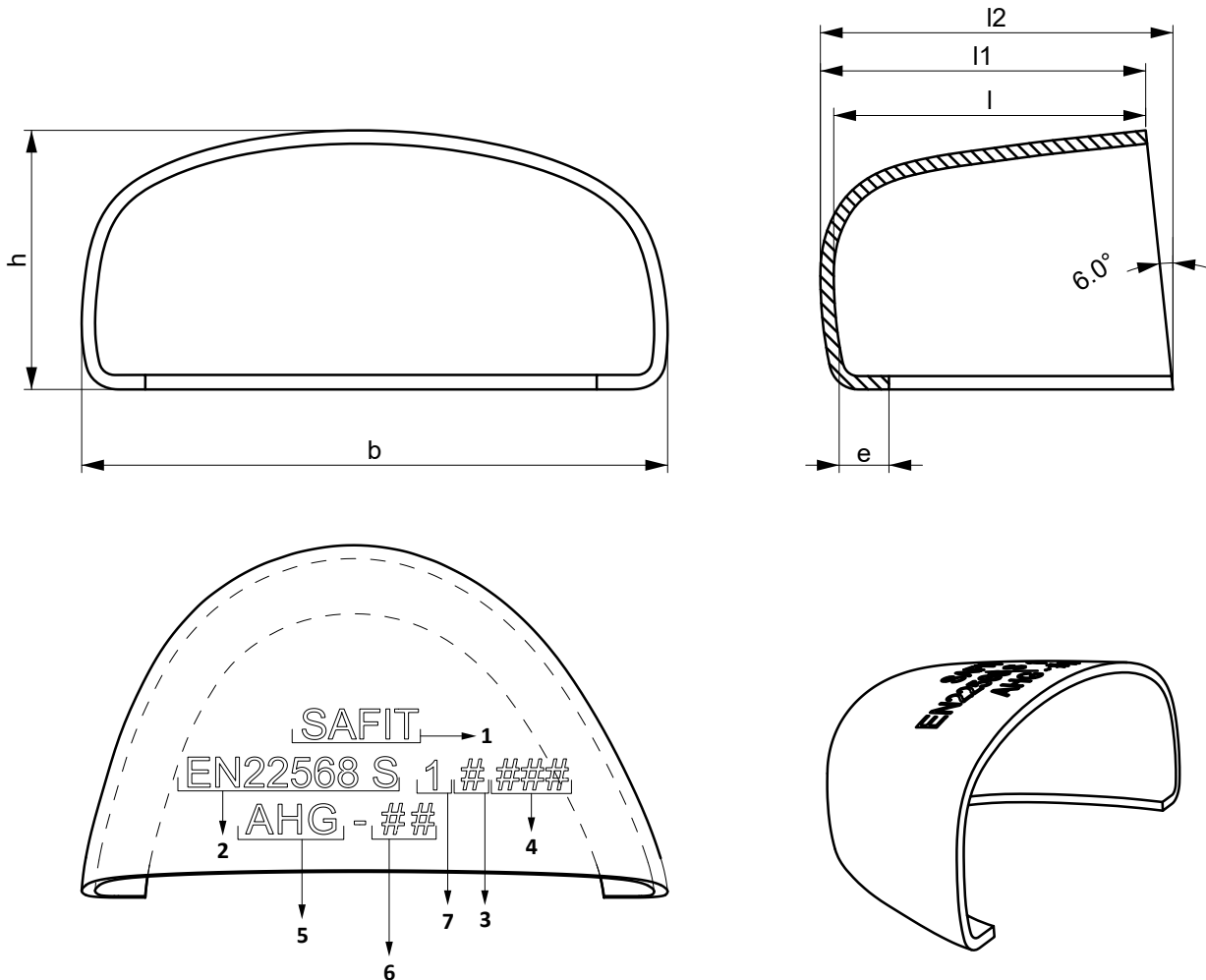

1	producer name
2	normative ref.
3	type A or B
4	batch number
5	model
6	size/R or L
7	metallic toe caps ref.

average hardness of steel releaved
on the top of the toe in the center position : HRc = 48 ± 2

dimension unit:		millimeter										KG	
Tolerance:		±0,05	±0,7	±0,5	±1	±1	±1	-2/+2	Minimal requirement of		Average performance		± 0,010
Size #	strip lenght - code ref.:	raw material thickness	b	h	l1	l2	l	e	ISO EN 22568:1 A	ISO EN 22568:1 B	200J	15KN	Weight (1 pairs)
2		2,0	77,1	34,0	42,5	45,0	40,5	8,0	19,5	24,0	20,0	28,0	0,154
3		2,0	79,0	35,2	43,9	47,0	41,9	8,0	19,5	24,0	20,5	28,0	0,160
4		2,0	79,5	36,1	44,5	48,0	42,5	8,0	19,5	24,0	21,5	28,0	0,160
5		2,0	79,0	36,5	43,5	46,0	41,5	8,0	19,5	24,0	22,0	28,5	0,164
6		1,8	84,0	39,0	48,0	52,0	46,2	8,0	20,0	24,5	22,5	29,0	0,194
7		1,8	88,0	38,5	50,0	55,0	48,2	8,0	20,5	25,0	22,5	29,5	0,186

Conformity to the norm Conforme alle norme	<input checked="" type="checkbox"/> ISO EN 22568:1 A	<input type="checkbox"/> ISO EN 22568:1 B	<input checked="" type="checkbox"/> ANSI/ASTM	<input checked="" type="checkbox"/> CSA
---	--	---	---	---